

■ AC Power Solution
Business Critical Continuity

Liebert GXT-MT + (1, 2, 3kVA Online UPS System)



 **Liebert**[®]

EMERSON[™]
Network Power



The Liebert GXT-MT +

True Online Double Conversion UPS With Extended Runtime Capabilities

- **Liebert GXT-MT+** features a comprehensive specification, satisfies safety criteria and electro magnetic compatibility standards, and offers intelligent monitoring and network management functions.
- **Liebert GXT-MT+** satisfies your requirements for high reliability and high availability of the AC power supply.
- **Liebert GXT-MT+** Making easily deployed in an office & Small / Medium industrial application.
- **Liebert GXT-MT+** long run model (L) deploys adaptive battery architecture to maximise your valuable rack space utilisation. Application specific battery configuration and placement ensures optimal performance with adequate power backup.



LCD Display



Note:- Liebert GXT-MT+ standard model is provided complete with internal battery.
Liebert GXT-MT+ (long back up model) application specific battery and cabinet available through your local Emerson Network Power representative.

True Online Double Conversion

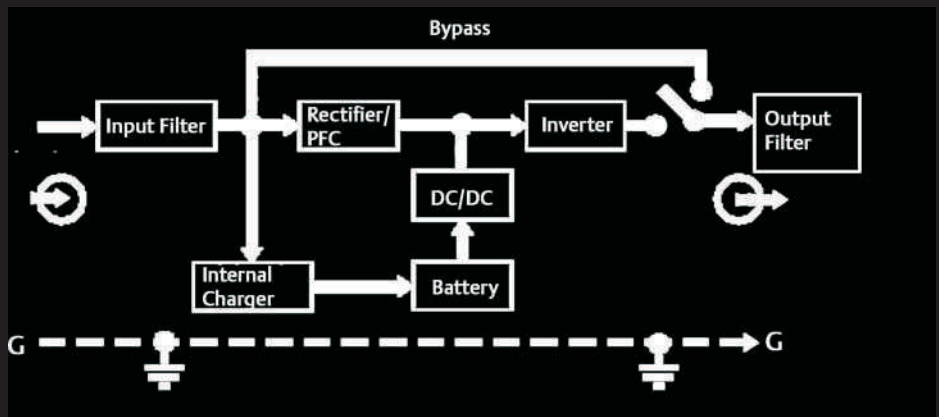

Applications

- Small Size Data Center
- Telecommunication, VoIP
- Small Office Network
- Data Warehouses
- Process Automation Equipments

Features

- 0.8 output power factor
- Emergency power off (EPO) [ECO mode]
- LCD display for status/fault information
- Configurable to energy saving mode (ECO)
- Extended Runtime Capabilities
- Flexible (Site Specific) Battery Configuration
- Compact Tower design
- Generator Compatible with wide input frequency range (40 to 70 Hz)
- Ultra wide input voltage range
- High capacity Battery Charger for long backup
- High input power factor & low THDi

Flexible Configuration

- Extended Run Time ready facilitated through a simple process of building up additional battery resources.
- Multiple AC output interfaces via IEC standard sockets with Programmable output.

Convenient maintenance

- Fault type is clearly displayed for fast troubleshooting.
- LCD display provides maximum operational convenience when managing the UPS.

Intelligent Management functions

- Stronger Battery charger on the GXT L model for quick recharge
- Remote Monitoring is available through USB/RS232, and optional via dry contacts and SNMP. The monitoring option software supports TCP/IP with event log and analysis function.
- Self-diagnosis and protection enable the auto shutdown of the client terminal or server under abnormal mains supply or when battery is over discharged.

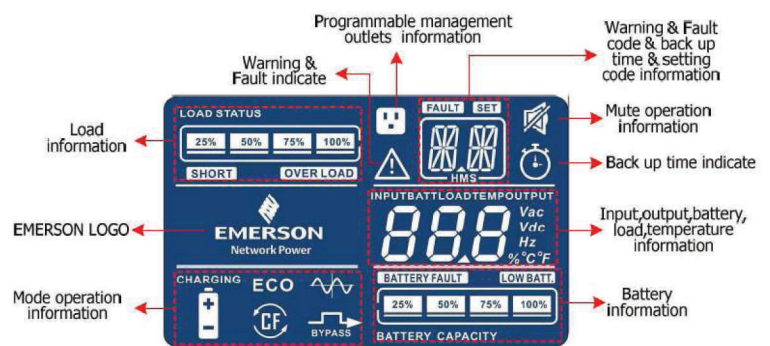

LCD Display of Liebert GXT-MT+

Technical Specifications

Model	1 kVA	2 kVA	3 kVA
OUTPUT PARAMETERS			
Capacity	1kVA / 800W	2kVA / 1600W	3kVA / 2400W
Power Factor	0.8		
Nominal Voltage	220 / 230 / 240 Vac		
Voltage THD	<=3% - Linear Load <=6% - Non Linear load	<=4% - Linear Load <=7% - Non Linear load	<=4% - Linear Load <=7% - Non Linear load
Frequency Regulation - Free Run (Unsynchronised with bypass)	+ / - 0.5 Hz		
Frequency Regulation (Synchronised with bypass)	47.5 - 52.5 HZ / 57.5 - 62.5 HZ		
Creast Factor	3:1 max.		
AC - AC Efficiency	88% R-Load, 87% RCD - Load		
Transfer time - Mains to battery	0 millisecc		
Transfer time - Inverter to bypass - Synchronisation mode	4 msec		
INPUT PARAMETERS			
Configuration	1 phase, L-N + PE		
Nominal Voltage	230 Vac		
Voltage range	160V to 300V at 100% Load, At 60% Load 110V to 300 Vac		
Frequency	50 / 60 Hz		
Frequency range - Hz	40 - 70 Hz		
Power Factor	0.95		
BATTERY CHARGER			
Nominal Voltage - Float (SB Model)	41 Vdc	82.1 Vdc	82.1 Vdc
Nominal Voltage - Float (LB Model)	41 Vdc	110 Vdc	110 Vdc
Maximum charging current - STD. / LB.	1A - STD and 8 A - LB		
BATTERY PARAMETERS			
Type	SMF		
No. of battery blocks (SB Model)	3 X 7 Ah	6 X 7 Ah	6 X 9 Ah
Battery Voltage (LB Model)	36 VDC (3 Battery Blocks)	96 VDC (8 Battery Blocks)	96VDC (8 Battery Blocks)
ENVIRONMENTAL PARAMETERS			
Operating temperature	0 to 40 deg. centigrade		
Storage temperature	-20 to 50 deg. centigrade		
Noise level	>=45db		
MECHANICAL PARAMETERS			
Height X Width X Depth (MM)	220 X 145 X 388.5	318 X 190 X 387	318 X 190 X 387
Weight	13 kg. - STD., 7 kg. - LB	26 kg. - STD., 13 kg. - LB	28 kg. - STD., 13 kg. - LB
Colour / Panel finish	RAL 7016 dark grey		
Protection	IP20		
Communication Port	RS232, USB		
EPO (Emergency Power off Mode)	Yes		
MONITORING SOFTWARE	SNMP, dry contact card, UPSilon 2000		
STANDARDS			
EMI	EN 62040-2: 2006		
SAFETY	EN 62040-1-1: 2003		
PERFORMANCE (technical feature)	IEC / EN 62040 - 3		

Emerson Network Power

The global leader in enabling Business-Critical Continuity™

- AC Power
- Connectivity
- DC Power

- Embedded Computing
- Embedded Power
- Monitoring

- Outside Plant
- Power Switching & Controls
- Precision Cooling

- Racks and Integrated Cabinets
- Services
- Surge Protection

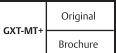

Country Office

Emerson Network Power (India) Private Ltd.
Plot No. C-20, Road No. 19, Wagle Estate,
Thane (W), Maharashtra - 400 604. India.

Toll Free No 18002096070

www.emersonnetworkpower.com
marketing.india@emerson.com

Emerson Network Power and the Emerson Network Power Logo are trademarks and service marks of Emerson Electric Co.

© 2010 Emerson Electric Company

For disposal of Batteries Please visit the below link:
<http://www.cpcb.nic.in/divisionsofheadoffice/hwmd/lead.pdf>

Note: Specifications & Features may vary based on the condition.

Q5 - BR - PRD - 1 - 18 - 03
07 / 11